

The role of disruptive innovation in the development of luxury watch industry

Čukman, Marko

Undergraduate thesis / Završni rad

2021

Degree Grantor / Ustanova koja je dodijelila akademski / stručni stupanj: **University of Zagreb, Faculty of Economics and Business / Sveučilište u Zagrebu, Ekonomski fakultet**

Permanent link / Trajna poveznica: <https://um.nsk.hr/um:nbn:hr:148:813963>

Rights / Prava: [Attribution-NonCommercial-ShareAlike 3.0 Unported/Imenovanje-Nekomercijalno-Dijeli pod istim uvjetima 3.0](#)

Download date / Datum preuzimanja: **2025-02-25**



Repository / Repozitorij:

[REPEFZG - Digital Repository - Faculty of Economics & Business Zagreb](#)



University of Zagreb
Faculty of Economics and Business
Bachelor degree in business

**The role of disruptive innovation in the development of luxury
watch industry**

Marko Čukman, JMBAG: 0067575170

Mentor: Ph.D., Goran Vlašić

Zagreb September 14th, 2021

Name and family name of student

STATEMENT ON ACADEMIC INTEGRITY

I hereby declare and confirm with my signature that the _____
(type of the paper)
is exclusively the result of my own autonomous work based on my research and literature published, which is seen in the notes and bibliography used.

I also declare that no part of the paper submitted has been made in an inappropriate way, whether by plagiarizing or infringing on any third person's copyright.

Finally, I declare that no part of the paper submitted has been used for any other paper in another higher education institution, research institution or educational institution.

In Zagreb, _____
(date)

Student:

(signature)

Abstract: Watch is often regarded not only as a thing which shows time, but as a way to express yourself and say a lot without saying anything. This exact thing is what luxury watches industry is based on, watches that represent the wearer through their brand perception and brand image. Brands such as Audemars Piguet, Rolex and Swatch have been building the brand image for dozens of years now in order to approach the highest number of buyers possible. Aside from the brand image, the brands are developing technology which separates them from the competition. Disruption created by the brands mentioned in this paper has left an indelible impact on the world of watchmaking. What is even more, disruptive innovators are the ones who have positioned the industry in the position where it is today, and their importance will be understood to the fullest in the future when all the work they have done comes to the surface.

Keywords: Disruptive Innovation, Luxury Watches, Rolex, Swatch, Tag Heuer, Seiko, Jean-Claude Biver

Table of Contents

1. Introduction into the thesis	1
1.1. Aim of this paper.....	1
1.2. Methodology	2
1.3. Structure of the paper	2
2. Basics of disruptive innovation.....	3
2.1. Introduction into the disruptive innovation	3
2.2. The book that started it all – The innovators dilemma.....	5
2.3. 5 principles of disruptive Innovation	7
2.4. Disruptive innovation as a part of a business model	8
2.5. Disruptive innovation in big companies.....	9
2.6. Criticism of disruptive innovation theory.....	11
3. Introduction into the luxury watch industry	12
3.1. Overview of the luxury watches industry and brand positioning	12
3.2. Luxury watches within disruptive innovation framework	13
4. Disruptive innovators in luxury watches industry.....	15
4.1. Gerald Genta – The greatest watch designer	15
4.2. Jean-Claude Biver’s revolution at Hublot.....	17
4.3. Independent watchmaking.....	20
5. Disruptive innovation in luxury watch industry	21
5.1. Rolex, and its win at disruptive innovation	21
5.2. Creation of the first quartz wristwatch	25
5.3. Creation of Swatch.....	28
5.4. Smartwatch innovation	31
5.5. Tag Heuer Tourbillon creation.....	35
5.6. Importance of Casio G-Shock.....	37
6. Effects and consequences of disruptive innovation.....	39
7. Conclusion	40
8. Literature.....	42
List of figures.....	49

1. Introduction into the thesis

Watch industry had been an important segment of the Swiss GDP as well as a part of their national identity due to which they will do everything to protect the industry and to stay as competitive as possible. Especially in the times when the technological development brings numerous challenges to all industries. During the 20th century, as well as in the first 20 years of the 21st century there had been several disruptive innovations which impacted the Swiss industry and made it improve its business operations and invest more into technological development of its products in order to be competitive on the market. People such as Gerald Genta, Jean-Claude Biver as well as the independent watchmakers are the ones that stand behind the innovations and propel the innovative thinking throughout the whole watchmaking industry. At the same time, disruptive products such as Swatch, G-Shock and Smartwatches are the ones that make the industry go forward and develop further. Lastly, the disruption created by the Rolex throughout the last 100 years made the whole watchmaking world think about the power of a single company and its impact on the competition.

1.1. Aim of this paper

The aim of this paper is to present as well as to explain the most important disruptive innovations in luxury watches industry. What is more, the goal is to understand the importance of each of the innovations for its time and location where it had been envisioned in the first place. The industry of luxury has to keep up with time and latest technology due to its price as well as because of brand reputation. The paper will explain the importance of the disruptive innovation and power of disruption one brand can cause with the development of a certain feature for its product. This paper will explore the motivation behind the innovation, its impact on the market in the past and importance of the innovation in today's world. Lastly, this paper has a goal to make the complex world of watchmaking closer to the reader.

1.2. Methodology

The purpose behind this paper is to cover innovations of utmost importance for the industry, such as the creation of quartz wristwatch and the crisis which followed. Some innovations had an incredible impact on the watchmaking industry, but it did not affect any other industries, such as tourbillon innovation. On the other hand, the story of Rolex or Smartwatch creation impacted industries around the world. What is more, this paper will explain how did innovators such as Jean-Claude Biver or Gerald Genta leave an indelible mark on the luxury watches industry. The primary data for this paper are Croatian and international sources such as online scientific publications, articles, books, and reports. Some of the reliable internet sources such as official websites will be included in the paper as well as interviews and statistical data.

1.3. Structure of the paper

This paper is divided into six main chapters. In the first chapter disruptive innovation and its proponents will be introduced. Second chapter will create an introduction into the field of luxury watches to understand the connections, holding companies, relevant individuals as well as other relevant information. Chapter number three will get into details about the most important individuals in the industry, the ones that stood behind the changes and made other embrace them. Fourth chapter will explain the disruptive innovations which are not related to only one person but created by whole companies or holdings. Chapters five and six will sum up all the disruption presented in first four chapters and create a conclusion as well as sum up the impacts and consequences of the disruptive innovations in luxury watches industry.

2. Basics of disruptive innovation

2.1. Introduction into the disruptive innovation

Back in the mid 1990s Clayton Christensen had developed a phrase “Disruptive innovation”, the term has been buzzing around the business world now for over two decades. What does disruptive innovation exactly mean? Disruptive innovation is an idea based on the disk drive industry in the end of the 20th century¹. Disk drive industry had experienced a great number of changes throughout the late 1990s. The development in disk drive field consequently led to decreases in disk size and increases in the storage capacity. As the new and smaller disks were developed, initially they were not able to store as many data as their bigger and older counterparts. Due to that customers did not appreciate the technology and it had been extremely hard for engineers to get funding for the development processes. It is exactly what led a great number of companies in that industry to fail. The best example of the incredible failure in the disk drive industry is Seagate. Seagate had been a leader in the 5.25-inch disks for a long period and had a dominant position in the market. As the time passed, they developed a 3.5-inch disk, but its capacity had been significantly lower than the 5.25 one, 10MB compared to 40 or 60MB. It led to a decrease in the resources given to the department which dealt with 3.5-inch disk, and consequently to giving up on the idea of a 3.5-inch disk. At that same time disappointed workers of Seagate decided to form their own company and focused on 3.5-inch disks which they managed to develop to the level that they were able to serve mainstream customers. This disk sales allowed them to make Seagate a second-tier supplier of disks because Seagate never managed to keep up with the 3.5-inch disk production. Seagate had decided to enter the market of smaller disks in the moment when it had become a mainstream, since the sales of those disks were able to satisfy the financial expectations of the company. This happened since, in order for a project to be relevant for a large company, it is important for it to be able to create revenues as soon as possible, in the case of Seagate, the managers were not able to see that potential.

Disruptive innovation by definition describes a process in which a smaller company

¹ Bower J.L., Christensen, C.M. (1995, January - February). Disruptive Technologies: Catching the Wave. Harvard Business Review.

whose resources are not as abundant as some of its competitors are, manages to compete with them on the same level due to its superiority in a certain field. It often is a case that a richer and more experienced company decides to shift their focus to the most profitable customers and consequently neglects all the others. This is when a more flexible company comes in and takes away a part of the market which is neglected. Disruptive innovation really defines its power in the moment when the newcomer starts taking profitable customers from the incumbent company. Also, it is important to mention the fact that disruptive innovation does not occur every time a newcomer succeeds with a start-up and gathers new customers. Simply because some of the technological start-up's do not upset the old guard. Lastly, disruptive innovation is not a single business decision or a product release, it is a set of decisions, products and procedures throughout a period of time among a number of other things that in the end create the big picture we all see and admire.

To put the theory into the perspective, according to the article published by Harvard Business Review², it is a relatively common situation that the company which initially invented a certain thing such as a copy machine invention by Xerox, or IBM when it comes to computers end up second in the sales numbers. Companies such as Cannon for copy machines or Apple in the computers case have been a definition of a disruptive innovation. Companies which created a new product were not able to see the future, the products were not marketed in the appropriate way, which consequently led to the opportunity for competition to take a part of the market through seeing the future and understanding the potential future customer. The dangerous area when having a new product is the process of adaptation of the product for customer needs, companies which listened to their customers when it comes to product development often lost their competitive advantage³ due to the fact that customers in most of the cases have no idea what is good for them. The best examples of that are mentioned in the initial article devoted to disruptive innovation - "Disruptive technologies: Catching the Wave". Technologies such as large-scale Xerox machines, Bucyrus Erie excavators as well as

² Bower J.L., Christensen, C.M. (1995). Disruptive Technologies: Catching the Wave. Harvard Business Review

³ Christensen, C. M. (2001, January 15). The past and future of competitive advantage. MIT Sloan Management Review.

IBM large computers were created and then developed further via the customer requests and in accordance with their preferences. But it is exactly those preferences which led them to decrease in sales and consequently become second option for the customer.

“In each instance, companies listened to their customers, gave them the product performance they were looking for, and, in the end, were hurt by the very technologies their customers led them to ignore. “– Catching the wave⁴

2.2. The book that started it all – The innovators dilemma

The innovators dilemma is a book written by Clayton Christensen in 1997 and published by Harvard Business Review. Clayton Christensen had been a professor at Harvard Business School where he taught a course called “Building and sustaining a successful enterprise”. According to his official biography he is regarded as one of the most influential thinkers in the world. He has been awarded many times for his books and articles in which he talked about the disruptive innovation and its impacts. What is more, prior to his career at Harvard Business School he worked for Boston Consulting Group and started several his own enterprises.

The book further extends and talks about the term “disruptive innovation” which has been introduced for the first time in an article published by Harvard Business Review as well, called “Disruptive Technologies: Catching the Wave”⁵. The book mainly concerns companies which have failed even though they were well respected and admired. What is more, they were also well managed and did not have any significant problems such as arrogance, bureaucracy, or poor planning, on the contrary, they were investing, listening to customers, and still managed to fail. The book concerns primary markets that are moving fast as well as the ones where constant evolution of technologies occurs.

In order to understand The Innovators Dilemma, there are a number of “insights” which are very useful when trying to make the most out of the book, they concern customers, managers, innovation, money etc.

It is important to keep customers close but listening to what they need in a given moment will often lead to decrease of sales in the future, at least according to the historical

⁴ Bower J.L., Christensen, C.M. (1995). Disruptive Technologies: Catching the Wave. Harvard Business Review

⁵ Bower J.L., Christensen, C.M. (1995). Disruptive Technologies: Catching the Wave. Harvard Business Review

examples. Next relevant topic when talking about innovation is money. According to prof. Christensen, it will be very hard to motivate managers to allocate resources towards disruptive innovation because of the fact that they are a lot riskier and will need a lot more time to return the investment.

„Disruptive technology should be framed as a marketing challenge, not a technological one.“⁶ – When creating and marketing an innovation it is very important to be aware of the fact that it might not be accepted right away by the mainstream customers, which is why a company should try to aim at a completely new market with that product. Regarding the managers, it is important for them to be aware of the capabilities of the company in which they work. Often case is that managers are not completely familiar with all the processes a company can complete, as well as at which levels of production can company stay profitable. Organisations are constantly developing, changing and adapting to the environment, because of that it is important for managers to at each point know the capabilities of the organisation as well as its limits and boundaries. For managers information is what makes a change, when you are able to get information in the right time, it is a lot easier to decide on some issue. The problem when talking about disruptive innovation is the fact that often information is simply not available at a given time. Organisations which do not tolerate failure in sustaining the innovation often do not tolerate failure in the disruptive ones either. Sometimes managers can be the ones who facilitate and embrace innovation, they have to be ready to fail, rise again and potentially fail once again. What is more, the managers have to decide constantly where to put the company in order to be the most successful possible. One company should not have only the role of a disruptor, company as it changes its forms, should sometimes change its role from a disruptor, to the one who sustains the innovation, since that is often considered as the best strategy for an organisation which thrives to stay in the market for as long as possible. Lastly, disruptive technologies in their early forms rarely make sense and they in general seem doomed for failure. This is where the opportunity of small companies lies in. Large competitors simply do not have time nor motivation to create the disruption in that way, their main focus is to create revenues and to satisfy

⁶ Christensen, C. M. (1997). The innovator's dilemma: When new technologies cause great firms to fail.

existing customers. For managers in those organisations, it is extremely complicated to create an environment in which the disruptive innovation is facilitated and approved. The managers that manage to create a context for innovation, who manage the organisation values, perception, structure and general capabilities for disruptive innovation in a company will often be recognized as very successful.

2.3.5 principles of disruptive Innovation

The principles of disruptive innovation are laid down by Prof. Clayton Christensen in his book called “The innovators dilemma”. The goal of the principles is to give a sound explanation why managers cannot use the same practices all the time, and to show that sometimes practices which are the most productive regarding existing technologies are the most unproductive regarding the disrupting the industry. What is more, he suggests which strategies are to be used in order to become the most effective in both fields. First of the five principles states that “companies depend on customers and investors for resources”, since companies have to earn money, they are selling products which their customers and investors buy and approve. Consequently, there is a system as well as an increasing amount of bureaucracy levels which kills any creativity and ideas. Due to that, customers are not offered new products until it is too late, and they have to shift to some other producer.

Second one talks about the fact that “small markets don’t solve the growth needs of large companies”. This principle concerns the constant need for growth of large companies, investors will always thrive to increase the prices of shares through increased revenues of the company. Due to that the company is not able to focus onto the small markets since there is not enough time for a small market to grow and show its full potential.

Third principle states that “Markets that don’t exist can’t be analysed”. When you have a unique product, your market still does not exist, when you create a disruptive innovation, you sometimes cannot quantify your market and due to that there are certain occasions when sound market research and planning are not the best thing to do.

Fourth one states that “organizations capabilities define its disabilities”, which means that the capabilities of people in one field are often their disabilities in the other field.

It would make no sense to judge a fish by its capabilities to climb a tree, in the same way it makes no sense to expect from a camel to swim.

Last but not the least principle says that “technology supply may not equal market demand”, or simplified, once the technology offered to a customer is having similar performance, customer will be looking at other elements of a product in order to satisfy his need. According to the Prof. Christensen, those elements are things such as reliability, price, convenience, but, adjusted for today’s perspective, it can be said that emotions are becoming more relevant here compared to price, convenience, or reliability. The importance of those five principles is not only relevant for the given company, but also for the partners, competition and other potential associates⁷.

2.4. Disruptive innovation as a part of a business model

The definition of disruptive innovation mentioned before mainly concerns customers whose needs have not yet been satisfied, the prices of products which do not satisfy their needs are too high and the products are complicated or unattainable. The importance of disruptive innovation as a part of a business model is in the fact that in that case the innovation is not only facilitated in the production or sales departments, but as well as within the segments of day-to-day operational activities, which allows a company to grow bigger and faster⁸.

Often, if one would be asked to name a company which can be classified as a disruptive innovator, the person would say UBER, but according to the framework of disruptive innovation UBER is not a part of the process⁹. The authors of the article “What is disruptive innovation?” Explain that by stating that UBER did not find a low-end opportunity, because there were not too many taxi vehicles nor were they too easy to use or too clean. And neither they targeted noncustomers. They managed to attract new customers to taxies, but that was not their primary focus. UBER in this case did opposite of disruptive innovation, they focused on existing customers and their transfer to UBER

⁷ Christensen, C. M., Anthony, S. D., & Roth, E. A. (2004). Seeing what's next: Using the theories of innovation to predict industry change.

⁸ Dyer, J., Gregersen, H. B., Christensen, C. M. (2011). The innovator's DNA: mastering the five skills of disruptive innovators

⁹ Christensen, C.M., Raynor, M.E., McDonald, R. (2015, December). What is disruptive innovation? Harvard Business Review.

application, and then consequently attracting new customers.

The authors of the Harvard Business review took Apple as an example for disruptive innovation, and since later in this paper there will be more words about Apple and their disruptions, it seems a logical idea to explain general approach to business model in disruptive innovation through Apple's concept. Apple iPhone had been released in 2007, and if we take that idea on its own, it might not be much different than the one related to UBER and their concept. But, aside from the obvious innovation found in iPhone, there is much more to it. The phone on its own has been extremely successful and superior compared to other phones in the market at that moment. But the things that came later is where the disruptive innovation lies in. At the moment of introduction of the first iPhone, personal computer had been a primary source of internet access, but due to the constant improvements of Apple networks, applications and all other physical and non-physical periphery they managed to change the complete playing field. In that way, it created an entirely new business model which had its base supported by disruptive innovation. Furthermore, we can see the success of their concept and business model in an incredible number of competing companies today, from Samsung, Xiaomi who are in the same line of business, to cars and of course luxury watches. In the case of Apple, disruption was something that lead them to success, but of course the disruptive idea might not always work in the way one expects to. As it has been the case with Pebble smartwatch which did not manage to cope with the competition and customer requests.

2.5. Disruptive innovation in big companies

According to the research presented in the book¹⁰, during the history often big companies have been filled with bureaucracy due to which it was extremely complicated to facilitate disruptive innovation since it needed a lot of adaptation and forward thinking. Bureaucracy and entrepreneurship are often found to be mutually

¹⁰ Kuratko, D.F., Goldsby, M.G., Hornsby, J.S. (2018). Corporate Innovation: Disruptive Thinking in Organizations.

exclusive but, as the time went by, this had changed to a certain degree.

Big companies work in conjunction with universities or research institutes in order to boost innovation and disruption within their operation, since it is complicated for corporations to balance innovation and at the same time protect their traditional way of doing business. The further complication comes when it is realized that to facilitate innovation the team has to be motivated, new goals have to be defined and communication has to be improved, and all of that at the same time while doing all the things which were done before the innovation process started.

What is important to note is the fact that the thrive for innovating and entrepreneurship is an individual skill which one should either poses or be ready to embrace throughout their working life in a corporation. The goal when trying to create an entrepreneurial environment within your company is to develop a corporate innovative philosophy. It leads to atmosphere which supports innovation, and which motivates people to work towards innovation. Having a philosophy also helps the company to keep the competitive posture as well as to keep the important people and motivate them even further.

Furthermore, when innovation is facilitated in corporations, it is of utmost importance to have managers who understand and are able to cope with the innovators. Managers have to lay down the ground rules. They have to give their innovative teams a certain level of independence in order to allow them to think, but at the same time the “gravity” has to be defined, what is acceptable and what is not. After presenting the team with the goal of their project, managers have to be able to clear some potential problems which might arise in the process of problem solving. Lastly, they must control and monitor everything, with a goal of further development of the opportunity. The potential for disruptive innovation could lie in each organization¹¹, but it is up to their management and employees on whether they will embrace it in the manner that helps them to develop the corporation in the desired direction.

¹¹ Christensen, C. M. (2006, January) The Ongoing Process of Building a Theory of Disruption. The Journal of Product Innovation Management.

2.6 Criticism of disruptive innovation theory

According to the article published in 2015 by A. King and B. Baatartogtokh¹² the theory of disruptive innovation as presented by prof. Christensen in the 1990s might not be the most accurate one. They state that the initial research made when the theory's foundation had been laid had some flaws due to which the theory might be wrong. It is said that there had only been a few quantitative research made when the theory had been in the process of creation, and what is even more, the ones that were made state that most of the managers respond in the right manner to potentially disruptive threats. Which is contrary to the framework laid down by prof. Christensen. The research process conducted by the articles authors was to take 77 examples of disruption and test them according to the principles of the disruptive innovation. The research led them to the conclusion that most of the 77 examples did not comply with all the key elements of disruptive innovation. Experts which were part of the research were supposed to define whether the example complies with the key elements.

Does that than mean that the advice given in *The Innovators Dilemma* are wrong? According to the article, both yes and no. The theoretical framework of disruptive innovation is still relevant if certain conditions are met. The problem is that a lot of the theory is based on the “disk drives” industry which complies 100% with the theory of prof. Christensen. Most of the other examples satisfy some of the elements, but not all of them. The best example is the one taken from a teaching course coauthored by prof. Christensen, which describes a startup company which wants to create an ultra-thin camera. Due to the framework of disruptive innovation, it had been taught that the incumbent company in the industry would not want to compete with the startup, due to the disruptiveness of a thin camera. But what happened is that the incumbent company jumped to the innovation and the startup had been squeezed out of the market. These examples tell us that every company is unique, and even though a manager knows the principles of disruptive innovation, it should not always stick to them, even if the other conditions are met. The power of a good manager is an ability to differentiate between the real disruptive power of a certain innovation and a trend which will fade.

¹² King, A.A., Baatartogtokh, B. (2015, September). How Useful Is the Theory of Disruptive Innovation? MIT Sloan Management Review.

3. Introduction into the luxury watch industry

3.1. Overview of the luxury watches industry and brand positioning

To understand the luxury industry, its players, and rules, firstly there is a need to talk about the ownership, relations, price positioning of the brands and holding companies, as well as to introduce some terminology needed to understand each element of the paper. Most of the luxury watch brands are owned by big holding companies. The most famous of those companies is Moët Hennessy Louis Vuitton (LVMH) whose chairman and CEO, Bernard Arnault had been the richest man in the world¹³ for a brief period in 2021. What is more, Arnault is not only the CEO of the LVMH, but also, in partnership with his family controls 47,5% of the LVMH shares¹⁴. LVMH, aside from the three brands which are part of the holding name, holding controls Christian Dior, Kenzo, Rimowa, Sephora and many more. Regarding the watch brands they control TAG Heuer, Zenith and Hublot. Bulgari and Tiffany & Co. are also under their ownership and both brands have lines of watches, but they are primarily credited as jewellery mansions. Regarding LVMH, it is important to note that they have divided their watch division into price brackets, TAG Heuer being the cheapest and Hublot the most expensive. Swatch Group is the second holding company, the group is primarily focused on watches and watch related technologies. Brands such as Swatch, Longines, Omega, Blancpain, Breguet and many more are owned by the Swatch Group. Also, aside from the watch manufactures Swatch Group owns brands such as ETA, which is an extremely important watch movement manufacturer and Renata batteries, probably the most popular button batteries on the market. Third and the group with highest number of luxury watch brands in the industry is Compagnie Financière Richemont, they own brands such as Cartier, A. Lange & Söhne, IWC, Panerai and many more. When talking about Richemont it is important to mention that they purchased controlling shares in MR Porter, Yoox and Net-a-porter which shows that they believe retail will go online and brick and mortar stores could lose their importance. Last important holding company is Kering, owned by Francois Henri Pinault. Kering owns brands such as

¹³ Forbes. (n.d.). Worlds Billionaires List.

¹⁴ LVMH. (n.d.). Capital Structure.

Gucci, Saint Laurent, Brioni and other. Regarding the watch mansions, Girard-Perregaux, Ulysse Nardin and Jean Richard is what they have. These four groups control majority of the luxury brands out there, but still, there are a few more holding groups such as Seiko which owns Seiko and Grand Seiko. Also, Casio who produces G-Shock watches as well as calculators and a great deal of other small electronic devices.

Aside from big holdings, there are still some brands that exist in the market due to their heritage, uniqueness, or simply amazing business models. First of those is Audemars Piguet who is still owned by the founding family. Second one is Patek Philippe, owned by the Stern family since 1932. Lastly, the most interesting and widely recognized is Rolex. Rolex is at the moment ran by Foundation Hans Wilsdorf, and according to Swiss law, if you are a charitable foundation, you are not obliged to present financial statements to public. That would not be such an interesting thing if Rolex weren't the most sought after and popular watch brand in the world. Due to it being a foundation, no one really knows how many watches they produce, nor how much do they earn.

Besides holdings and big companies, there are several smaller watch manufacturers who propel the growth of the industry through small but equally disruptive innovations. Some of those would be MB&F, Francois Paul Jorune, Kari Voutilainen, Philippe Dufour or Russian watchmaker Konstantin Chaykin. All those watchmakers and brands are together called "Independent watchmakers" or just "Independents".

3.2. Luxury watches within disruptive innovation framework

Industry of luxury watches can be considered as an old and extremely inflexible when it comes to accepting new trends from industries such as fashion or technology, but sometimes it is exactly that tradition which made them successful and relevant. Knowing its ruggedness, it still managed to embrace a number of innovations, of which some had a disruptive impact on its business operations and even changed the direction in which will it go in the future. The innovation that had the most impact throughout the whole industry, country of Switzerland and the world in general is the invention of quartz wristwatch, to be more precise, the consequence of the quartz wristwatch, the Quartz crisis, which is considered as a very dark period in the Swiss history. Aside from that, there had been several smaller innovations, as well as some people who managed

to disrupt the industry in more than one occasion, which nowadays makes them extremely appreciated. What is important to stress out, when talking about the disruptive innovation in luxury, that it has a bit different understanding of disruptive innovation, in the world of luxury watches a tourbillon¹⁵ movement watch priced at 40 000CHF might be a reasonably priced watch, so if a brand manages to sell the same thing for 15 000CHF, combined with an innovative campaign, unique approach and similar level of quality, it will be disruptive for the industry.

¹⁵ Type of a watch movement which is regarded as exclusive and complex to execute

4. Disruptive innovators in luxury watches industry

Innovations are a very important aspect of each industry, and, of course, behind the innovations there are often people who are able to look years or even decades into the future in order to create something that would simplify the lives of people around the world. Consequently, it is to expect that there are a few relevant innovators in the luxury watch industry. Innovators mentioned in this paper are some of the most important people in industry of watches and some of them made an impact that will be talked about for hundreds of years.

4.1. Gerald Genta – The greatest watch designer

Gerald Genta is a Swiss watch designer who had a great impact on the watch industry with his disruptive and trendsetting designs. According to the web page of Gerald Genta Association, he designed more than 100 000 watches¹⁶. He was born in Geneva in 1931 and passed away in 2011.

Even though Gerald Genta does not satisfy the framework of the disruptive innovation as Clayton Christensen formed it, the importance and the disruption, in the common perception, caused by these designs had been something that defined the trajectory of the watchmaking industry, whether it being the bottom or top price segment. He satisfied to that point a non-existing segment of the market. What is more, after his designs, luxury sports watch had become a way to enter the Haute Horology and it motivated a lot more people to purchase brands such as Patek Philippe or Audemars Piguet. During his lifetime he designed watches for a great number of brands, such as Universal Geneve, Omega, Cartier, IWC, Seiko and many more. His two greatest watch designs were Audemars Piguet Royal Oak and Patek Philippe Nautilus. According to the official website of Gerald Genta he got the inspiration for the Royal Oak from a diver's helmet which had been attached to the rest of the suit with eight screws, and the inspiration for the Nautilus came from a transatlantic ship.

¹⁶ Gerald Genta Heritage (n.d.) His Story



Figure 1 - Audemars Piguet Royal Oak and Patek Philippe Nautilus

The two designs were the most disruptive watch designs of the 20th century, they are the ones because of which today market is flooded with luxury steel watches and why people are sometimes willing to pay more for steel than for gold watches. The disruption of the industry empowered by these two watches had an incredible impact on the world of luxury watches today. These two watches, and later IWC Ingenieur were the first watches which had an “integrated” bracelet. On most of the watches there is a spring bar between the lugs¹⁷ of the watch that connect the bracelet or a leather strap to the case of the watch. In the case of Gerald Genta design, the bracelet is “integrated” into the case of the watch. It still is removable, but from an esthetical design perspective, integrated gives a more elegant and modern look. Genta designs, were the ones that redefined the market, and even created a completely new one.

‘Disruption comes from breaking the rules’¹⁸ and that is exactly what happened in the case of revolutionary watch designs in the second half of the 20th century. Until that moment, no one had been willing to connect the term ‘luxury watch’ with steel, to incorporate a bracelet into the case, and lastly, believe that companies such as Audemars Piguet and Patek Philippe will release a luxury steel sports watch.

¹⁷ Crown and Caliber. (n.d.). Anatomy of a watch.

¹⁸ Anthony, S.D., Johnson, M.W., Sinfield, J.V., Altman, E.J. (2008). The Innovator's Guide to Growth: Putting Disruptive Innovation to Work

4.2. Jean-Claude Biver's revolution at Hublot

„Watchmaking icon; watch industry legend; the guru of luxury watches; the saviour of the Swiss watch industry... “¹⁹— words taken directly from GQ magazine and written by Nick Foulkes who is a contributor at Financial Times, Vanity Fair as well as for GQ. If some further research is done, it is very visible that Jean-Claude Biver is an incredibly important person not only for the brand in which he works, but also the whole industry. The disruption some of his creations caused, whether they are of promotional character, or a physical watch is making headlines for years. JCB was born in Luxembourg in 1949 and his first job in watchmaking industry was in Audemars Piguet. Later in his business life he worked in Omega, Blancpain, Tag Heuer, Hublot... The important thing to note when talking about JCB is the fact that in which ever company he got, he disrupted the brand or even the industry sometimes. The uniqueness of his approach is the fact that he is one of the rare people who did everything to understand the people who work for him.

„Listen. In 1980, what did you do? You took rubber from the trees, and you took gold from under the Earth. You combined two elements from the Earth that could not meet. A bee and a flower, they meet. A cow and grass, they meet. You fused two elements together on the planet that did not go together, and you made a ‘fusion.’” Crocco disagreed with me and said he chose rubber because it was waterproof. I said, “Yeah, but philosophically, you made a fusion. So today, in 2004, I will say that we have a new mission, a message. The message of Hublot is ‘Fusion in watchmaking art.’ From today on, we have a religion. Now we know what needs to be done to fulfil this vision of ‘fusion.’ It’s not just an aesthetical exercise with rubber and gold. It is a philosophical concept— to fuse. We can fuse together other things beyond rubber and gold. We can fuse carbon and gold, we can fuse our tradition to the future. It’s an attitude. “²⁰

¹⁹ Foulkes, N. (2018, September 20). Why Jean-Claude Biver is so much more than a successful Swiss watch boss. GQ magazine.

²⁰ Raffaelli, R.L. (2016, March 14). ‘Jean-Claude Biver (B): Leading Change at Hublot’. Harvard Business School.

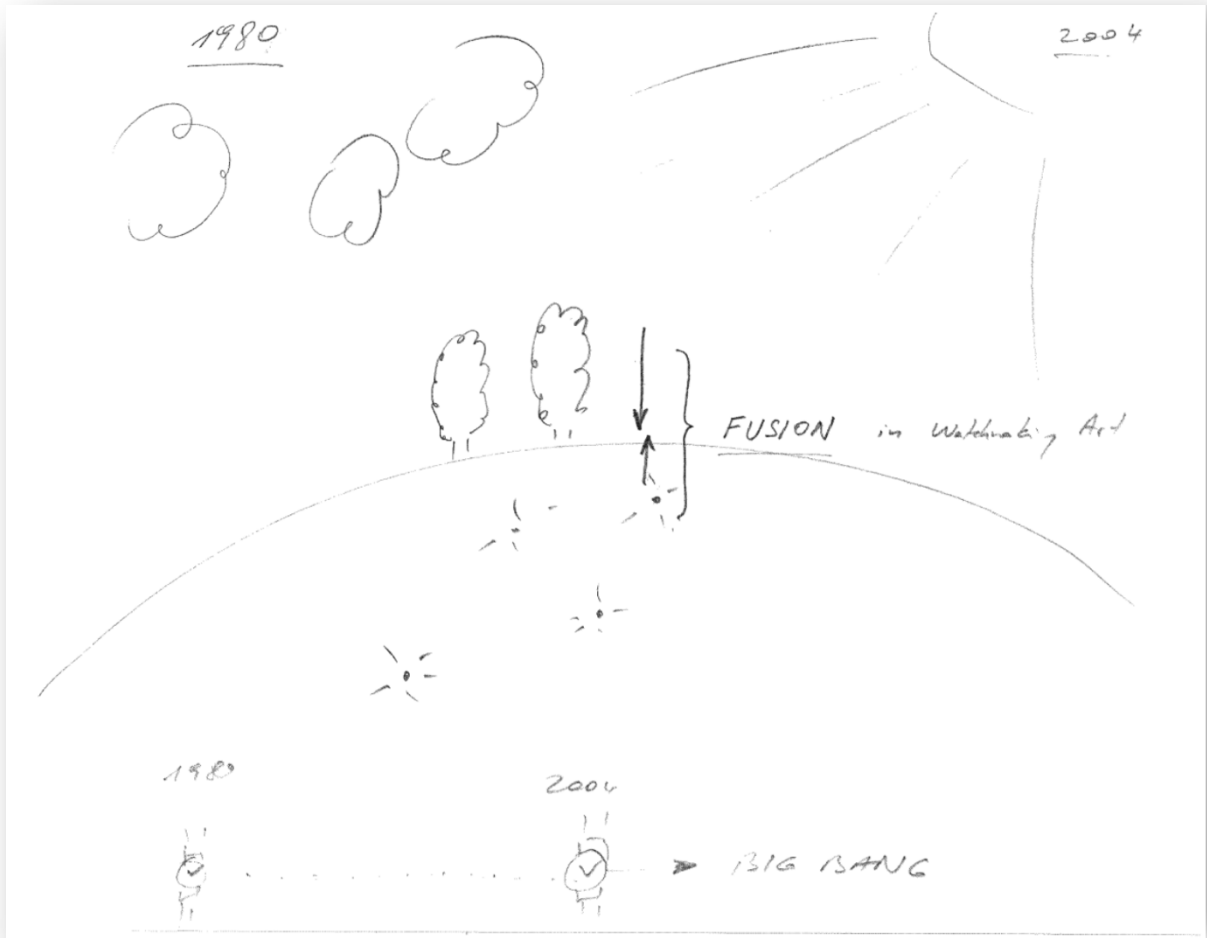

Figure 2 - Vision of 'fusion' for Hublot

Sourced: Raffaelli, R.L., (2016) 'Jean-Claude Biver (B): Leading Change at Hublot

The story of Hublot and the mastermind behind its creation might not disrupt from the bottom end of the market, but what Jean-Claude Biver did to Hublot and consequently the watchmaking world is a disruption to the level unexplored until then. Hublot had been founded in 1980 by Carlo Crocco. Uniqueness of the brand laid in its design and usage of natural rubber strap for the first time ever on a precious metal watch. The watches until 2004 were small, they were selling bad, and the brand seemed to be doomed to fail. But, in 2004 Jean-Claude Biver had become the CEO of Hublot. After his appointment he coined the term “fusion” which explained the “fusion” of precious materials with rubber, which had until then been outrageous for a luxury watch.

According to P. Donzé, “Biver developed this concept and redefined the true nature of luxury watches using new materials and targeting new categories of wealthy customers”.²¹ When it comes to Hublot and its media presence, JCB developed that even further, he developed media presence of Hublot on every social media platform. Once he said. “Wherever the buyer looks, he must see Hublot.” What is more, he, according to Ryan Rafaeli, would hand out handwritten warranties to customers. And, lastly, and the craziest of all, while eating at restaurants, if he saw someone wearing a Hublot, he would pay their bill and hand over his business card with a thank you note for supporting Hublot. He brought Hublot to people, he made people believe that Hublot is something attainable to them, he made it attractive, he was offering a “Patek combined with a Rolex”²², which is something unseen in the market before. According to both the interviews in video format which Jean-Claude Biver had given, and the texts written about his work, he had been a man of analysis. „Every analysis that I did, came out the same: one should buy Hublot.”²³ Hublot is a brand with clear product which had not at that point been prostituted, he said. Biver often says that there are three things of crucial importance when launching a new product, it is important to be first, different, and unique.

What had been unique in the perspective of Hublot is the fact that for 100 000CHF you are able to purchase a watch which has high complications such as a tourbillon, but at the same time it looks sporty and durable. Back in 2004 that has been revolutionary. Luxury watches such as Audemars Piguet and Patek Philippe had complications, but they were not meant for any physical activity. Hublot brought tourbillon complication to more people, to people who did not commit to wearing suits and wanted something a bit more modern and fashionable. What is more, you were not supposed to keep Hublot’s in your safe deposit box but wear them all the time. Hublot had made the similar thing Swatch did, but in a different price segment. It revolutionized an existing product in order to create completely new market and bring new customers to watches as well as to the brand.

²¹ Guttman, M. (2019). *Historians on Leadership and Strategy*.

²² Jean Claude Biver talks Hublot. (2013, October 16). Jason Lim [YouTube Channel].

²³ Thompson, J. (2018 October 25). *Personalities Jean-Claude Biver And The Making Of The Modern Watch Industry*.

4.3. Independent watchmaking

Independent watchmaking is a term coined in late 1990s when there had been an increasing number of watchmakers who were not a part of any large conglomerate or company, and their goal had been to emphasize the expertise directly to the customer and through creations like never seen before. They have a focus on quality, incredible details, and extremely low production numbers. Aside from few mentioned before, best representatives of the independent watchmaking are Laurent Ferrier, Uhrwerk, Rexhep Rexhepi, Vianney Halter and many more.

The disruption among independent watchmakers lies in the uniqueness of their product. At the beginning, some 20 years ago their products were of lower quality, had not so attractive and interesting designs, which consequently did not lead to overall appreciation of brands and high sales numbers. But as the time passed, their watches were becoming more and more advanced, attractive and the attention to detail on those watches is what separated them from the mass produced²⁴ ones. What is more, during the times that independent watchmaking made its first steps, there was no real competition in the market. It was simply a part of the market which did not exist before. The big players whose prices were similar to the prices of the independents simply did not care too much about small number of the enthusiasts who wanted something extremely special and unique. Brands which are part of the independents group mainly operate in the 50 000CHF and above price range. Even though by the book interpretation of the disruptive innovation mainly concerns bottom of the market, for the people who purchase 100 000CHF+ watches, independents are affordable, and they have created a disruption of their kind for the established brands which operate in the same price range. Lastly, as it has been mentioned several times before, disruption is not about one or two things, it is about a process, the process when it comes to independent watchmaking relates to the opportunity to become a part of a special small group of people who own a certain brand. There are millions of people who own Rolex or hundreds of thousands who own Audemars Piguet, but there are less than a thousand who own a Kari Voutilainen.

²⁴ In this case, a mass-produced watch is considered a watch brand that has more than 1000 pieces per year. Some independents make less than 50 watches per year.

5. Disruptive innovation in luxury watch industry

5.1. Rolex, and its win at disruptive innovation

Rolex is the most popular watch brand in the whole world, period. Founded in 1908 in Switzerland by Hans Wilsdorf, who previously produced watches and sold them to retailers who then branded them as they wanted. Post 1926 all the watches sold by Mr. Wilsdorf had to carry the Rolex name. Hans Wilsdorf has been a visionary whose focus had been to improve the watch as much as possible and make it as reliable as he could. Due to his aggressive approach and a number of innovations in the field of watchmaking he is regarded as one of the most important people in not only the watchmaking industry, but also engineering, business and marketing industries.

Rolex is one of very few brands that managed to stay on the top of its disruption and kept the disruption going for a very long time. Things have started back in 1926 with a first innovation which made a big impact. It had been called “Oyster concept²⁵”. Back in the early 1900’s it was a serious problem to keep the water, dirt, and dust out of watches, especially to keep them out of the crown, stem, and crown tube²⁶ assembly. What Hans Wilsdorf did is purchase the patent which could help him solve the water resistance problem.

²⁵ Escapenet Patent Search. (n.d.). Rolex Oyster case patent on July 30, 2021 [Data File]. Patent no. CH143449A

²⁶ Via the crown we wind the watch, stem connects the crown to the movement. Stem goes through the tube, and crown threads to the tube.

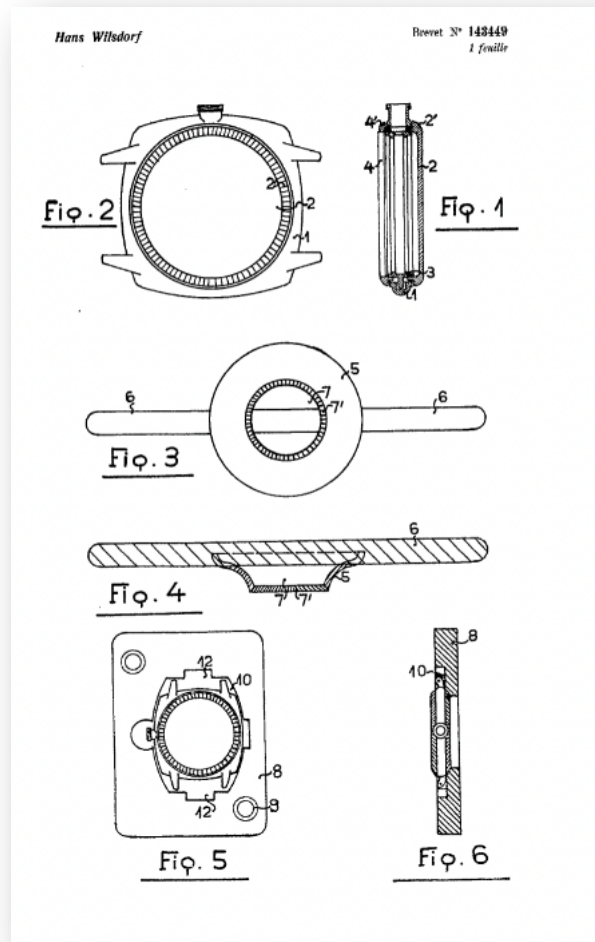

Figure 3 - Patent for the Rolex Oyster case

Patent no.: CH143449

Only a year after the purchase he persuaded Mercedes Gleitze²⁷ to wear a Rolex Oyster watch during her attempt to swim the La Manche. Unfortunately, she did not succeed in her intent, but no water had been found in the watch she wore around her neck. This had been one of the first marketing attempts from Hans Wilsdorf in order to introduce people to Rolex watches. After success with the Oyster case, he realized that some of his customers simply forget to screw down the crown, and due to that water and dust still manage to enter the watch. That happened because of the need to manually wind the watch. First self-winding movement has been created by British watchmaker John Hardwood, but Wilsdorf and Rolex watchmakers managed to improve the initial design of the movement and in that way created the movement Rolex calls 'Perpetual'. Very

²⁷ Mercedes Gleitze. (n.d.). Mercedes Gleitze Biography.

simplified, on the existing hand wound movement bottom, rotor had been added to wind the watch. This created the movement type which is today called “automatic”, which will work for as long as you are wearing it, since the movement of your hand makes to rotor to rotate, and consequently wind the watch.

During the 1930’s, 40’s and 50’s there were only 4 brands who were trying to create a diving watch, Omega, Panerai, Blancpain and Rolex. Omega and Panerai managed to create their watches in the 30’s, but their design is not anymore considered as a modern diving watch representation. Blancpain released its iconic Fifty Fathoms²⁸ diver in 1953, just a year before the first Submariner was released, in 1954. Even though it is not the first, it is the only one that had been on the market every year since its release. Omega discontinued its Marine²⁹ model, Panerai had been struggling during the 70’s and 80’s, and Blancpain went under during the Quartz crisis.

According to Harvard Business Review article Wilsdorf started giving fish tanks to his dealers to present the abilities of Rolex watches³⁰. Wilsdorf had pioneered celebrity brand endorsements, after Mercedes Gleitze, he sponsored Swiss water polo team, Sir Malcolm Campbell who had broken the speed record a number of times, as well as the first expedition to the top of Mount Everest which had been completed while wearing a Rolex Oyster Perpetual. He did not stop there, Rolex became the official watch of Pan American airlines with the GMT Master model, which had been an incredible success for the brand, and made brands offering more than just watches, it made them status symbols.

All the things mentioned were a part of the process of the popularization of Rolex through disruption, an important step for becoming what they are today. In the watch world they are perceived as mainstream.

Pricing is also an important element when talking about both Rolex and disruptive innovation, according to the information available online³¹, which for Rolex is quite

²⁸ Blancpain Fifty Fathoms - <https://www.blancpain.com/en/fifty-fathoms-collection>

²⁹ Omega Marine - <https://shop.hodinkee.com/products/1930s-omega-marine?variant=47970301327>

³⁰ Jones, G., Atzberger, A. (2015, September 15). Hans Wilsdorf and Rolex. Harvard Business School.

³¹ Minus4Plus6. (n.d.). Rolex Price Evolution.

hard to find, the price of a Submariner model in the USA in 1957 had been 150\$ which adjusted for inflation in 2021 is equivalent to 1.416,00\$. The retail price of today's Rolex Submariner is 8.100,00\$. For reference, Patek Philippe ref.3417 in steel had a retail price of 500\$³² in 1959. To put that into perspective in 1957 annual wage had been on average 4,713\$, compared to today's which is 51,480.00\$ so even with basic calculations we can see that Rolex has become much more exclusive in the 2021 than it was in 1957. In 1957 you had to work only 11.6 days to buy one, whereas in 2021 you have to work more than two months. The most interesting fact now when the prices are evident, is the fact that the watch had minimal changes since 1957. As it is evident from a picture below. Latest model has been presented in 2020 and to an untrained eye it looks exactly the same as the one from 2010, and even extremely similar to the one from 1984.



Figure 4 - Rolex Submariner Models

³² Christie's (2021) What are the 10 most desirable Patek Philippe references?

What is even more, Rolex decided to create a disruptive innovation for itself, by creating Tudor. Since they were aware of the fact that their prices might not be accessible to all of the customers that might want a Rolex, in 1946 Tudor had been formed in order to produce more accessible watches. By doing that they managed to capture even the customers who were not able to pay for a Rolex, and at the same time bring the money under the same roof. What happened here is that Rolex decided to focus on their most profitable customers, but aware of the fact that there should be a cheaper alternative and in order to prevent their competition disrupting their business model, Rolex placed Tudor in the more affordable price segment and in that way “disrupted themselves”. Tudors were marketed to a younger population to teach them to wear a watch and then just lead them to buy a Rolex later in life. That model can be one of the reasons why Rolex did not feel a touch of the smartwatch revolution.

In the book ‘The Innovator's Guide to Growth: Putting Disruptive Innovation to Work’ one of the principles of disruptive innovation states ‘Business model innovation often powers disruption’, which has a great similarity to the success of Rolex and its business model. This model connects numerous segments such as marketing, distribution, sales, and a number of other in order to provide a product which gives the end buyer a feeling of satisfaction, a feeling of success. What is even more, after the initial disruption in the 20th century, they managed to sustain the innovation, by constantly improving the products and business model in the way that none of the competitors is able to even remotely approach them and endanger their position as a market leader.

5.2. Creation of the first quartz wristwatch

Seiko is a Japanese watchmaking manufacture whose story started in 1881 in the Japanese capital, Tokyo, with a 21-year-old Kintaro Hattori. At the beginning it had been a retail and watch repair shop, but as the time passed, he founded Seikosha, company which produced wall clocks. In 1924 it was the first time Seiko name appeared on a wristwatch and 45 years later Seiko introduced Quartz Astron, the world’s first quartz wristwatch.

On the Christmas Day in 1969 Seiko Quartz Astron 35SQ had been released to the public. This watch started and era in the watchmaking industry which changed things from the ground up. It was the first time that a quartz watch was publicly offered for sale anywhere in the world. 200 pieces of Quartz Astron were made, of which 100 sold during the Christmas week. Back in 1969 the Astron had been priced at 450 000JPY, which translated into today's money equals to almost 1.6 million JPY³³, and around 13 350CHF. To put that into perspective, an entry level Toyota Corolla in 1969 started at 450 000JPY.

Seiko Quartz Astron's accuracy had been in +/-5 sec per month³⁴. For reference, Rolex mechanical watches in 2021 have a declared accuracy of +/-2 seconds per day³⁵. That is exactly why quartz watches became so popular, what is more, the maintenance needed in order to keep a quartz watch operating is minimal, one is supposed to change the battery every two or more years, which costs you couple of CHF. In the mechanical watches sphere, you have a cost of at least 100CHF, and it can range all the way up to thousands for servicing and maintenance, every 5-7 years on average.

The disruption of this Seiko lies in the fact that until its release there hasn't been anything similar which could impact the mechanical watch industry to that level. Only a few years later Quartz crisis started, which is without a doubt the worst period for luxury watch industry since its creation hundreds of years ago.

On the opposite side of the world, Swiss were working on a quartz movement of their own, but the problem laid in the fact that big companies who had resources to develop the movement had no interest to do so, because of that, many small companies had to join forces in order to keep up with Seiko. The reason for a very slow response from the Swiss is the fact that they had numerous standards as well as trained people and repair men who would become obsolete with the quartz creation. They thought that keeping up with quartz watches will be considerably easier, so they tried to accommodate their old ways of conducting business to the new times and technologies. Unfortunately for the Swiss, Seiko had a lead in the development of quartz watches, and by the late 1970's

³³ Inflation calculator. (n.d.). Calculator.

³⁴ Seiko Epson. (n.d.). Seiko Quartz Astron 35SQ.

³⁵ Forster, J. (2018, February 19). How Accurate Should Your Mechanical Watch Actually Be? Hodinkee.

they were exporting quartz watches all around the world, at lower prices than Swiss counterparts. What is more, within the framework of disruptive innovation, Seiko had a watch cheaper, more reliable, and simpler to use. And as a bonus, it was fashionable to wear a quartz watch.

Even though quartz watches are on their own an incredible innovation, and they improved the industries worldwide, that would have not happened if they were not marketed in an appropriate way, the Japanese realized that they cannot market the quartz watches in the same way they or the Swiss market mechanical ones. Asians decided to ignore all the traditional marketing concepts which always included jewellers. They created brand recognition and product lines, they focused on production of low-cost modules in order to reduce the price as far as they could in order to have a competitive product. The combination of a technology which was an incredible reach for 1969 with the new marketing perspective managed sell millions of watches throughout the 70's and 80's. What might be considered as a surprise is the fact that most of the large watchmakers ignored the quartz movement creation, it is hard to say the exact reason, but it is most probable to say that they did not consider the quartz movement to be able to impact their sales. The importance of quartz for the disruptive innovation framework lies in the fact that the creation of a quartz watch movement made wristwatches a lot more accessible to people. Compared to mechanical watches, quartz ones are very easy to operate and simple for daily use, which allowed many people who were intimidated by the need to take care of their watch, winding it and servicing to buy a quartz counterpart. As the consequence of the development of quartz watches by Seiko, the dark era called Quartz crisis started. According to some sources, in the period from 1970 to 1980 the number of watchmaking manufacturers almost halved. Even harder hit took the employment numbers, from around 90 000 employed in the watch manufacturers in 1970, the number decreased to 32 000 in 1990³⁶. What is important to note is the fact that it is not only the quartz watches that impacted the significant decline of Swiss watch production. Things such as global recession, appreciation of Swiss Franc and an increase in watch manufacturing activates in Asia³⁷. The development of Quartz

³⁶ Twinam, T. (2020, July 30). Trade Shocks and Growth: The Impact of the Quartz Crisis in Switzerland.

³⁷ Twinam, T. (2020, July 30). Trade Shocks and Growth: The Impact of the Quartz Crisis in Switzerland.

movement by the Japanese came as the icing on the cake, the drop that broke the glass and everything started to go downwards. It took the Swiss more than 10 years to create Swatch, the watch that saved the industry.

5.3. Creation of Swatch

The era of quartz watches had started in the late 1960s with the Seiko Astron, during the seventies there had been a great number of brands which tried to enter the quartz watch market, such as Casio, Seiko, and even some Swiss, like Omega. But it all went into the second plan in the exact moment when Swatch had been launched. Swatch watch has been a project of Nicolas Hayek Sr. with a goal to compete with the Far Eastern competitors, as well as to approach younger customers through designs that were colourful, cheerful and above all creative. Swatch launched in 1983 and since then it has been producing designs that create trends and impact a number of other industries. Furthermore, Swatch is a part of the Swatch Group, and according to some sources, Swatch has supposedly been the brand that saved the Swiss watchmaking industry, due to its incredible success among the customers. In 1993 Swatch had produced its 100 millionth watch.

The importance of Swatch watches lies in the fact that it pioneered in numerous things we today consider as completely normal. Swatch had been one of the first brands that had started the today extremely popular collaborations. Since 1984 Swatch has been doing collaborative watches with a great number of artists such as Keith Haring, Kiki Picasso, Vivienne Westwood, Damien Hirst and many more. Aside from the collaborations with people, they collaborate with cities in order to make 'destination special' watches. A number of cities in the world have a destination special Swatch model which is sold only in couple of Swatch boutiques in that country or city, since getting a watch as a souvenir is not such a bad idea. Swatch and its creator, Nicolas Hayek Sr. were not only involved into watch creating. In the early 90's in collaboration with Daimler-Benz, they created a car. Swatch Mercedes Art, or as the name of the car

is, SMART³⁸. Which created a disruption in the automobile industry, due to its size and capabilities.

Swatch in 1983 had a price of 50CHF, which made it one of the cheapest watches out there, and that is without a doubt one of the reasons of its success and its disruptiveness. According to Hodinkee³⁹ which is the most popular resource for horology related information, the fact that Swatch and Mr. Hayek decided to go to the bottom of the market is exactly what made them successful. The bottom of the market had at that point in time been completely unserved due to the fact that the process of making a mechanical watch had been overly expensive because of high labour costs. The process of automatization, usage of plastic and a movement which is significantly cheaper and simpler had made Swatch extremely popular and attractive to buyers. The revolution of Swatch also laid in the fact that it is made from only 51 parts and because of the construction of the case they were able to further save money and price it even lower. The assembly of parts had been different than at the competition which further reduced their costs, and also, since they did everything ‘in-house’ they were very fast to respond to any type of changes in the demand. Traditional watch producers needed years in order to produce a new design, Swatch needed only six months in order to get from the idea to a physical watch.



Figure 5 - Swatch models from 80's and 90's

³⁸ Daimler. (2007). Cooperation of Swatch and Mercedes-Benz.

³⁹ Thompson, J. (2017 October 10). Four revolutions parts 1 – 4. Hodinkee.

The icing on the cake in this situation had been the “Swiss Made” inscription. Historically Swiss Made had only been reserved for expensive and inaccessible watches, but because of the ingenuity of Mr. Hayek who is often credited as the saviour of the Swiss watch industry, they decided to keep the Swatch 100% produced in the, until then completely traditional and mechanical, Swiss watchmaking industry. It made the executives shocked, and according to the interview⁴⁰ creditors were not very happy either.

‘We have realized that “Made in Switzerland” is a driving factor for watches. [...] Consumers were willing to pay a premium price for a plastic Swiss watch.’ (P. Petersen)

Before Swatch you were not able to get a “Swiss Made” watch for 30, 40 or 50CHF, and now even the lowest end of the market had been offering a ‘Swiss Made’ watch, at that point in time there had been no competition in the bottom market and all of the competition had been ignoring that segment because of the fear that their decision to enter the bottom of the market will negatively affect the other brands in their portfolio. Even after Swatch got into existence, aside from the Japanese competition, there was no real alternative to Swatch in Switzerland.

What is more, since Swatch really did the disruptive innovation concept by the book, they also changed the game in the marketing activities. Managers at Swatch were aware that in the 1980s they were the first with that kind of product to offer, and due to that it was an extremely smart idea not to go by the rules. They managed to change the rules of marketing and brand positioning through Swatch. Understanding of the market led Swatch to positioning itself as a fashion accessory, even a luxury fashion accessory, rather than a functional and useful timepiece as its Japanese competitors did. Swatch watches became an extension of the wearer, you felt like you were able to express yourself through wearing of the newest Swatch, of the Swatch that corresponded best to your preferences and emotions that day. Advertising at Swatch was also understood in a different way, competitors did usual campaigns where they did their best to show why is their model better than the competition and which functions does it have. Swatch

⁴⁰ Taylor, B. (1993, March - April). Message and Muscle: An Interview with Swatch Titan Nicolas Hayek. Harvard Business Review.

went in totally different way, they again sold the lifestyle, they did campaigns using MTV videos, colours, collaborations with artists and in that way, they managed to approach an incredibly wide variety of people and each of them would find an element of the watch campaign which could correspond to their emotions. What is more, they decided to sell through department stores and similar more upscale retail outlets, compared to Japanese competition which did not target people of higher buying power. Lastly, Swatch decided to produce many models in relatively limited collections, whereas the Japanese did limited number of models in extremely large production numbers. That resulted in the ability of Swatch to approach the same buyer every year and offer him a newest model. Plus, the idea of having something that is not sold anymore will make the owner feel more special and give him an urge to wear the sold-out piece even more. Swatch ended up as an incredible success, there was finally a 'Swiss Made' product which could be sold to everyone because of its very low price, high quality and the creative and attractive models were a bonus to a modern lifestyle.

5.4. Smartwatch innovation

The history of smartwatches dates back to the 1982 when Seiko introduced the TV watch. It had been a wristwatch which aside from the usual functions included a small TV screen and an ability to watch TV channels on your wrist. As the technology developed there were better and worse solutions for a smartwatch as we know it today. In 2015 the first Apple Watch had been released and that event can be defined as the source of disruptive innovation in the field of smart wristwatches.

According to the Deloitte study conducted in 2020 it is evident that smartwatches affected the sales numbers of Swiss watches. From the table below it is evident that the sales of both apple and other similar smartwatches have increased significantly, whereas on the other hand, traditional watches sales have decreased.

Shipments of smartwatches vs Swiss watches (millions of units)

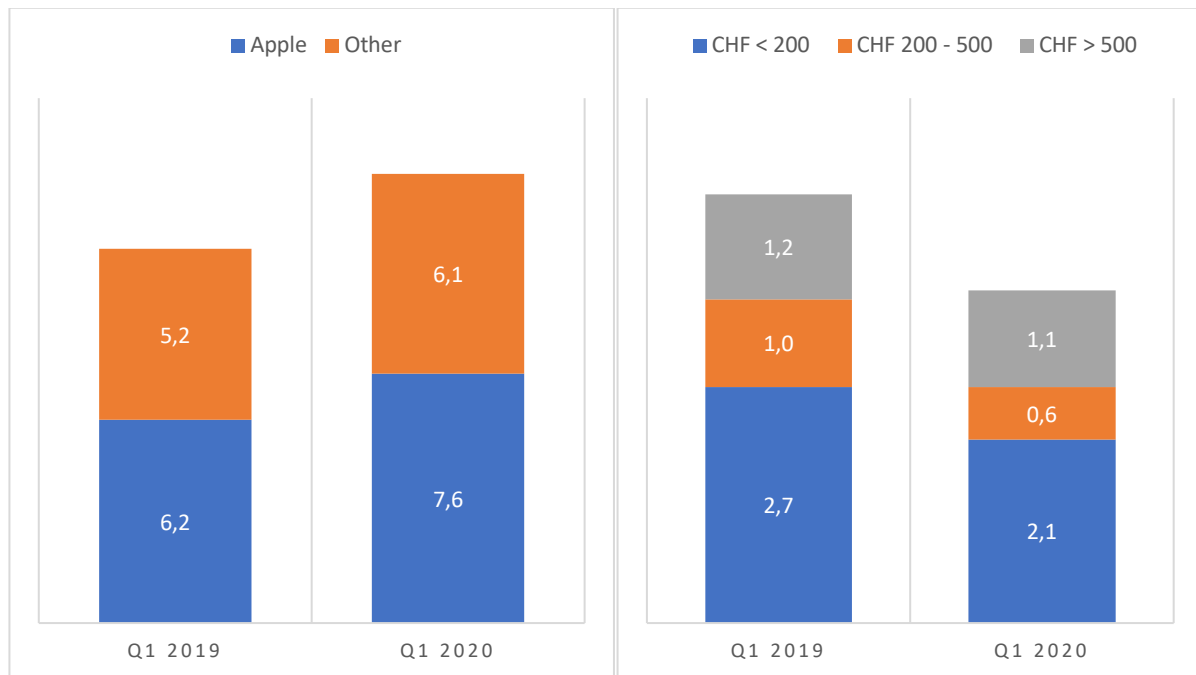

Figure 6 - Shipments of smartwatches vs Swiss watches (millions of units)

If we analyse the table into details, we can see that the decrease of less than 10% had occurred in the price segment of above 500CHF which leads us to conclusion that high end and luxury watches that bear the ‘Swiss Made’ sign are not affected in any way by smartwatches. With that in mind, below is a quote from one of the greatest businessmen in watchmaking.

“If you have never worn a watch, the effort to wear a watch is much bigger than if you have been wearing an information tool on the wrist since you were 15 years old.”⁴¹ – Jean Claude Biver answering a question regarding the potential obsolescence of the mechanical watch.

As long as we keep looking at the 500CHF+ segment of luxury watches no significant decreases are visible, but changes happening in below 500CHF are not even remotely good. Mid-tier segment which is priced from 200 to 500CHF had been hit the hardest. Decrease of 40% when comparing the same quarters of 2019 and 2020. This is where the disruption of the smartwatches took its toll. Manufacturers which operate mainly in that segment had been very late to the smartwatch revolution, they did not really

⁴¹ Switinbank, R. (2016). Jean-Claude Biver: ‘The Watch Industry Is Not in Trouble, The World Is.’.

understand the importance and the possible effects of smartwatches to their sales. The source lies in the fact that most of the better smartwatches are in the 200 – 500CHF segment. Because of that a number of younger and even some older buyers have decided to opt for the smartwatch since it is modern, useful and attractive piece of technology. For most of the people a mechanical watch under 500CHF does not produce the same level of satisfaction as a 9000CHF Rolex would. Due to the lack of the emotional connectedness, they have been deciding for the digital option since it at least made them modern.

“People have an emotional connection to high-end watches; they are timeless and the result of centuries-old know-how.”⁴² – Patrick Ravenswood

In the last segment where watches under 200CHF are located, decrease is significant, between 20% and 30%, which could lead us to conclusion that it had been as well impacted by the smartwatch popularization. The power of disruption among the smartwatches lies in the whole offer you get with a purchase. You are not only able to tell the time, but you also have fitness, health, messages, and a great number of other things incorporated into the smartwatch. The disruptiveness of the smartwatch and its main player Apple Watch have a similar concept as the Apple iPhone compared to historical idea of a mobile phone. The offering is much broader regarding the smartwatch compared to the traditional idea of a wristwatch whose main function is to show the time. Apple watch aside from the sheer fact that one has an Apple watch, offers a number of software’s for better usability, it offers a connection to your phone, it can act as a fitness tool plus all the regular wristwatch functions. The expensive watches have an emotional feature which no smartwatch will ever be able to replace, because of the tradition, knowhow, and the whole idea of having something that expensive on your wrist. What is more, since the Seiko TV watch, the prices had decreased significantly, and smartwatches have become a lot more accessible to an average buyer.

⁴² Deloitte. (2020). The Deloitte Swiss Watch Industry Study 2020 [EPub].

Smartwatch has been on the market for a very long time before Apple Watch had been introduced. But, as it had been always with the Apple products, the revolution started the moment their watch, in this case, had been released. What they did is collect all the failed attempts at a smartwatch, copied what is good, and trashed what was not. After all that, they added a bit of Apple character, which ended up as an instant hit. Apple had managed to get the mainstream customers, it had been the first smartwatch brand that managed to attract regular people to the watch and in that way create disruption for the Swiss industry. Swiss industry, having learnt the lecture from the Quartz crisis, had been much better prepared to embrace the smartwatch revolution and to adapt to the market trends, they are still at this moment, not taking seriously enough the smartwatch revolution, but they often say that it is an opportunity for them. By taking a look at the graphs below, in both 2017 and 2020 over 70% of the Swiss watchmaking executives do not consider smartwatches as a threat.

How do swiss executives rate the impact of smartwatches on their sales?

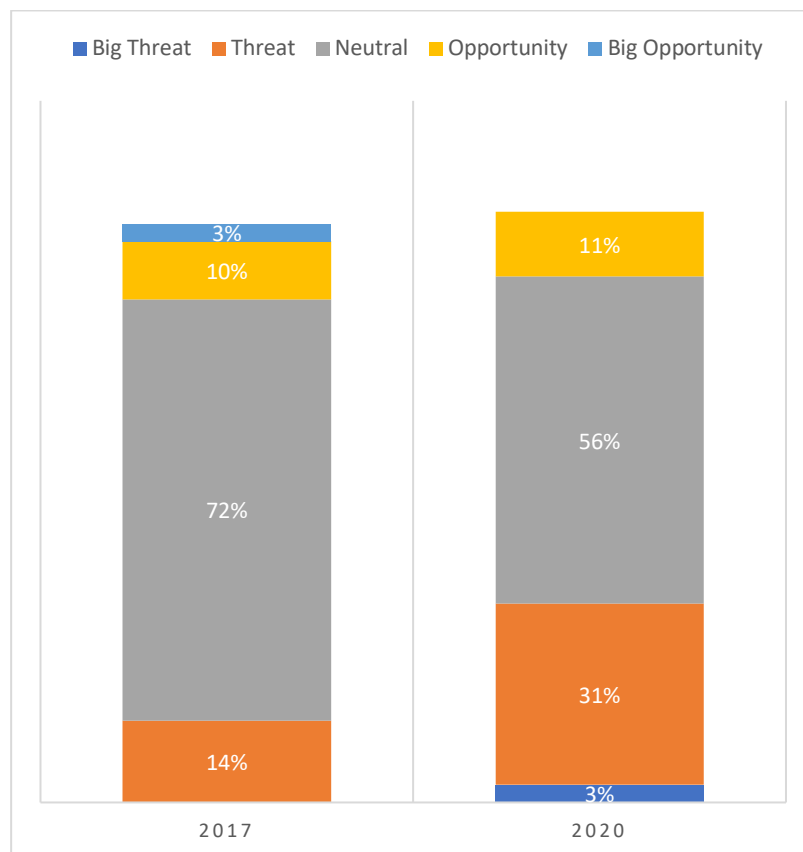

Figure 7 - How do swiss executives rate the impact of smartwatches on their sales

Even though there had been a great number of people who predicted a new Quartz crisis for the Swiss, until the moment of speaking, it is evident that there had been an impact of smartwatches and that certain price categories have experienced a fall in the demand, but the impact had been far from the Quartz crisis one. What is also important to mention is the fact that the smartwatch revolution is still on a positive trajectory, so there might be some activities that could disrupt the traditional watchmaking industry in the future.

5.5. Tag Heuer Tourbillon creation

Tourbillon is a complication which has been invented by Abraham-Louis Breguet, one of the best watchmakers at the time. The patent for tourbillon had been approved on June 26th, 1801, in France⁴³. Purpose of the tourbillon is to reduce the impact of gravity on to mechanical watches. Tourbillons are regarded as the most accurate mechanical watches in the market.

⁴³ Breguet. (n.d.). Tourbillon regulator invention.

Tourbillon complication has since its creation been reserved only for the most limited and exclusive watches produced by the most exclusive watchmaking mansions such as Patek Philippe, Vacheron Constantin or Audemars Piguet. Only the best watchmakers and the most respected mansions are able to manufacture tourbillons, at least until 2015 that was the case. As the time passed there were more and more companies entering the tourbillon complication field in order to try to get some customers with more affordable variations of the most luxurious complication put in the wristwatch.

Even though it may sound surprising, but Tag Heuer managed to disruptively innovate the tourbillon escapement in a mechanical watch in 2015. Under the command of Jean-Claude Biver Tag Heuer released a Carrera Chronograph which included a flying tourbillon. It would not be overly surprising, if it weren't priced at only 15 000CHF⁴⁴. For reference, Audemars Piguet, or Patek Philippe tourbillons are fetching well over 100 000CHF.

As it has been with a number of disruptions in luxury watch industry before, this had been a product of Jean-Claude Biver and his team. According to an interview he gave for a Swiss watch news channel, they were aware of the fact that nobody serves buyers who have around 20 000CHF and fancy a tourbillon, because of that they decided to focus on the supply chain arrangement in order to be profitable on the watch. They are aware of the fact that it will not sell in high numbers, but in order to position Tag Heuer in their desired location in the market, they had to show what the brand is capable of doing, and while doing that, they managed to disrupt the tourbillon market.

Without a doubt they are an underdog compared to the established brands who are producing tourbillons for a very long period now, but in this case, disruption is still very young. The market of tourbillons has experienced some decrease in prices and democratization, since a number of new players have entered in the similar way as Tag Heuer, but none of them managed to be priced lower, due to their need to outsource parts. Luckily for Tag, since it is a part of LVMH, it can use resources of the mother company.

Compared to Audemars Piguet or Patek Philippe, Tag Heuer is very cheap and

⁴⁴ Bredan, D. (2016, January 28). TAG Heuer Carrera Heuer-02T Tourbillon watch officially announced at 15,950\$. A blog to watch.

represents a bottom of the market, which makes this even more important for the world of tourbillons as well as more disruptive for most luxurious players, since there will be a lot more people who will be willing to buy Tag Heuer tourbillons than the ones that cost 10 or more times the price. Furthermore, in the accordance to the theory provided by Prof. Christensen, Tag Heuer managed to create a completely new market for tourbillon buyers, they even created completely new buyers, since before that one had not been able to purchase a Swiss tourbillon watch at the same price as a Rolex Submariner in gold-steel variant.

5.6. Importance of Casio G-Shock

Kikuo Ibe is a Japanese watch engineer and the person responsible for the creation of G-Shock watches. Casio G-Shock creation and the whole idea behind the brand is a great representation of disruptive innovation. G-Shock watches have been created in Japan in early 80's by a creative team whose goal had been to create a watch which will withstand all the possible torture one could give it. Watches had to satisfy rigorous standards such as centrifugal and impact forces as well as high water pressure. What is more, the whole concept of G-Shock watches had been something unseen until that moment. The watch consisted of two parts, all-round rubber protection and the movement. In that way the engineers managed to protect the movement from any kind of impacts since the rubberized outer elements of the watch took and cushioned all the impacts. Nowadays people consider G-Shock as a something completely regular or even common. Back in 1983 it created a disruption in every possible watchmaking area. The greatest attribute of the G-Shock when talking within the framework of disruptive innovation is the sheer fact that at that time in history there was no other company in the world who was thinking about the fact that for some people extreme conditions are part of their everyday life.

G-Shock was the first that decided to satisfy the customer who had been in the market for a durable and resistant watch that would create no worries for the wearer if used in tough conditions. Also, even the most basic G-Shock watches are equipped with stopwatch, date, day, month, countdown timer, alarm etc. all these complications were before available only at the most high-end manufactures of mechanical watches, and

the fact that all of them are located in only one timepiece is even more thrilling for the buyer. Also, high-end brands were focused on presenting their full gold or steel watches to keep the customers with them, consequently, not a lot of effort had been invested into understanding the fact that a great number of the people who were buying Audemars Piguet or Rolex are entertaining themselves with a physical activity, and they prefer not using their expensive watch while swimming or playing tennis, but they would prefer a G-Shock. Lastly, G-Shock watches in the 80's as well as today were priced extremely competitively, in the 1983 price had been 11,400JPY which amounts to 120CHF in today's money, or 77CHF in 1983 money. In 2021 entry level G-Shock costs around 70CHF⁴⁵.

⁴⁵ Svijet Medija. (n.d.). Casio G-Shock DW-5600 price.

6. Effects and consequences of disruptive innovation

Disruptive innovation had left an inerasable impact on the luxury watch industry, and of course the watch industry in general. Innovations such as quartz movement for the first time in the history made the Swiss watchmaking adapt to something new, even though it took them a lot more than it should, in the end they managed to survive and embrace the new technologies. As a consequence of Quartz crisis Swiss watchmaking industry had been crucified, but in the end, they managed to stand back up again and gave us Swatch which is without a doubt one of the greatest watches ever made, due to both its importance for Swiss watchmaking, as well for Pop Art and the modern society. Second biggest disruption in the 80's, aside from Swatch is the G-Shock, which gave everyone an opportunity to do any physical activity with a watch. The most incredible thing is the fact that even after almost 40 years, both G-Shock and Swatch are still managing to keep their initial idea and are sticking to the same basic concept when it comes to selling and producing watches. That is exactly why they have managed to survive all the ups and downs which were put in front of them. What is even more, they left a mark on all the watch lovers in the world. It does not matter how much money one has, he can always wear a Swatch or a G-Shock and will earn a respect from the watch collectors around the world. And that is where the power of Swatch and G-Shock lies in.

Smartwatch is expected to be the next big threat for the Swiss, but they are a lot better prepared than they were in the 60's, a number of Swiss executives even say that they are not afraid of smartwatches at all, but a certain degree of fear would not be such a bad idea. Lastly, the impact of Rolex watches and its business model on the overall watchmaking industry will be studied for years to come.

7. Conclusion

What is important to understand from the theoretical segment of disruptive innovation is that even though its initial framework had been laid down more than 20 years ago, and it had been created on the example from the 80's, it still can be applied to a great number of situations in the business sphere, as long as we are aware that the framework should not be followed 100%.

In conclusion, disruptive innovation explains a great deal of situations which occur in the business world. The importance of it lays in the fact that understanding disruptive innovation can give managers a completely different viewpoint and in that way create a competitive advantage in the field. Being familiar with the principles of disruptive innovation and at the same time being aware that the disruptive innovation could have experienced some alterations since its creation in the 1990s will allow managers to apply a right set of measures for the given situation. Disruptive innovation is applicable to each and every industry, that is its biggest advantage as well as its biggest disadvantage. Its power lays in the fact that it can completely change the playing field in an industry. What is more, the opportunity when talking about disruptive innovation is the fact that it will inevitably lead to the development in the given segment. Even if only one player persuades in the innovation it will inevitably lead to a technological or operational advancement in the area. This can be concluded from both disk drive industry, personal computer or even watchmaking industry.

From a personal perspective, the disruptive innovation and the general idea of disruption are very important for the managerial and business sphere. What is more, we can expect an increase in the amount of the disruptive technologies in the future, since the advancement of the technology is a lot faster than the general acceptance of the improvement among the people. What can also be concluded from the disruptive innovation theory and examples is the importance of early adopters of the products, since they are the ones who can lead a product to a success. Also, disruption gives a market the ability to regenerate, gives the new players an opportunity to leave their impact. That can be characterized as the beauty of disruption, companies which left their impact are now leaving the playing field to the younger ones. In the end, the ones

that profit the most from it are customers and regular people.

The importance of disruptive innovation on to the luxury industry, is in the fact that disruption managed to almost destroy the Swiss watchmaking industry with the innovation and the popularization of quartz wristwatches. Watch industry, and precisely luxury watch industry has gone through numerous changes throughout the last hundred years due to continuous improvement of technologies which led to both development of existing techniques in production, management as well as marketing and creating new ones. At the same time, an incredible amount of completely new products and business techniques had developed. Quartz watches had marked the end of 20th century in both positive and negative way. The technological advancement which quartz revolution led to had made the watch industry more flexible and ready to embrace the future and innovative way of thinking. What is important to mention, Rolex as a sole brand had made an immense impact on the industry, in both product and managerial/marketing procedures and operations. Even though it is not the most luxurious nor the highest quality watch in the market, its reputation which it managed to acquire due to the consistency in business operations and corporate behaviour has become the benchmark for all the other players in the industry, which emphasizes the power of disruption Rolex has managed to embrace. There are still a few challenges which the watchmaking industry has to overcome, but after the quartz crisis, every challenge put in front of them will seem very easy and simple to overcome.

8. Literature

A Collected Man. (2021, April 20). Four patents that changed the face of watchmaking. A collected man. Retrieved from <https://www.acollectedman.com/blogs/journal/patents-changed-watchmaking>

Anthony, S.D., Johnson, M.W., Sinfield, J.V., Altman, E.J. (2008). The Innovator's Guide to Growth: Putting Disruptive Innovation to Work

Bower J.L., Christensen, C.M. (1995, January - February). Disruptive Technologies: Catching the Wave. Harvard Business Review. Retrieved from <https://hbr.org/1995/01/disruptive-technologies-catching-the-wave>

Bredan, D. (2016, January 28). TAG Heuer Carrera Heuer-02T Tourbillon watch officially announced at 15,950\$. A blog to watch. Retrieved from <https://www.ablogtowatch.com/tag-heuer-carrera-heuer-02t-tourbillon-watch/>

Breguet. (n.d.). Tourbillon regulator invention. Retrieved July 18, 2021, from <https://www.breguet.com/en/timeline/1801-1823/milestones/tourbillon-regulator-7562>

Bucher, R. (2015). TAG Heuer CEO Jean-Claude Biver: Our Exclusive Baselworld Q&A. Watchtime. Retrieved July 28, 2021, from <https://www.watchtime.com/wristwatch-industry-news/people/tag-heuers-jean-claude-biver-exclusive-qa/>

Bureau of Labour Statistics. (2021). Usual weekly earnings of wage and salary workers second quarter 2021 [EPub]. Retrieved from <https://www.bls.gov/news.release/pdf/wkyeng.pdf>

Christensen Institute. (n.d.), Disruptive Innovation. Retrieved July 25, 2021, from <https://www.christenseninstitute.org/disruptive-innovations/>

Christensen, C. M. (1997). The innovator's dilemma: When new technologies cause great firms to fail.

Christensen, C. M. (2001, January 15). The past and future of competitive advantage. MIT Sloan Management Review. Retrieved from <https://sloanreview.mit.edu/article/the-past-and-future-of-competitive-advantage/>

Christensen, C. M. (2006, January) The Ongoing Process of Building a Theory of Disruption. The Journal of Product Innovation Management. Retrieved from https://edisciplinas.usp.br/pluginfile.php/4667048/mod_resource/content/2/Rdg%2054%20Clayton%20Christensen.pdf

Christensen, C. M., Anthony, S. D., & Roth, E. A. (2004). Seeing what's next: Using the theories of innovation to predict industry change.

Christensen, C.M., Baumann, H. Ruggles, R., Sadtler, T.M. (2006, December). Disruptive Innovation for Social Change. Harvard Business Review. Retrieved from https://www.cnid.cl/wp-content/uploads/2015/10/Disruptive-Innovation-for-Social-Change_2006.pdf

Christensen, C.M., McDonald, R., Palmer, J.E., Altman E.J. (2018, June 18). Disruptive Innovation: An Intellectual History and Directions for Future Research. Journal of Management Studies. Retrieved from <https://onlinelibrary.wiley.com/doi/full/10.1111/joms.12349>

Christensen, C. M., Raynor, M. E. (2003). The innovator's solution: Creating and sustaining successful growth.

Christensen, C.M., Raynor, M.E., Anthony, D.S. (2003, March 9). Six Keys to Building New Markets by Unleashing Disruptive Innovation. Harvard Business School Working Knowledge. Retrieved from <https://hbswk.hbs.edu/item/six-keys-to-building-new-markets-by-unleashing-disruptive-innovation>

Christensen, C.M., Raynor, M.E., McDonald, R. (2015, December). What is disruptive innovation? Harvard Business Review. Retrieved from <https://hbr.org/2015/12/what-is-disruptive-innovation>

Christie's. (2021). What are the 10 most desirable Patek Philippe references? Retrieved July 28, 2021, from <https://www.christies.com/features/10-Most-Desirable-Patek-Philippe-References-10024-1.aspx>

Clayton Christensen. (n.d.). Biography Retrieved July 24, 2021, from <https://claytonchristensen.com/biography/>

Courvoisier, F.H. (2019). Creative Swiss Watchmaking: a mix of art, industry, and marketing. 15th International Conference AIMAC 2019. Venice: Ca' Foscari University. Retrieved from https://www.researchgate.net/publication/335835501_Creative_Swiss_Watchmaking_a_mix_of_art_industry_and_marketing

Crown and Caliber. (n.d.). Anatomy of a watch. Retrieved July 28, 2021, from <https://www.crownandcaliber.com/pages/anatomy-of-a-watch>

Dähler, R. (2017). A Comprehensive E-Business Framework for Luxury Watch Companies (Bachelor's thesis). Zurich University of Applied Sciences. Retrieved from https://digitalcollection.zhaw.ch/bitstream/11475/1366/1/D%C3%A4hler_Rico_W.B.A.BO.GM%20%28PiE%29.pdf

Dan, Y., Chieh Chang, H. (2008). A Reflective Review of Disruptive Innovation Theory. PICMET 2008. Cape Town, South Africa.

Daimler. (2007). Cooperation of Swatch and Mercedes-Benz. Retrieved August 7, 2021, from <https://media.daimler.com/marsMediaSite/en/instance/ko/Cooperation-of-Swatch-and-Mercedes-Benz.xhtml?oid=9274445>

Delfs, T. (2017, September 28). Fifty years of the quartz wristwatch. FHH Journal. Retrieved from <https://journal.hautehorlogerie.org/en/fifty-years-of-the-quartz-wristwatch/>

Deloitte. (2020). The Deloitte Swiss Watch Industry Study 2020 [EPub]. Retrieved from <https://www2.deloitte.com/content/dam/Deloitte/it/Documents/consumer-business/The%20Deloitte%20Swiss%20Watch%20Industry%20Study%202020.pdf>

Donzé, P.Y. (2011, April). The comeback of the Swiss watch industry on the world market: a business history of the Swatch Group (1983-2010), Retrieved from <https://mpira.uib.uni-muenchen.de/30736/>

Drasković, N., Marković, M. i Petersen, C. (2018). The Early Days of Swatch: Birth of the Fast Fashion Watch Business Model. Retrieved from <https://doi.org/10.22598/mt/2018.30.1.93>

Dyer, J., Gregersen, H. B., Christensen, C. M. (2011). The innovator's DNA: mastering the five skills of disruptive innovators

Escapenet Patent Search. (n.d.). Rolex Oyster case patent on July 30, 2021 [Data File]. Retrieved from <https://worldwide.espacenet.com/patent/search/family/004400026/publication/CH143449A?q=Ch143449>

Federation of the Swiss watch industry FH. (n.d.). The new requirements stipulated by Swissness Retrieved July 28, 2021, from <https://www.fhs.swiss/eng/swissness.html>

Forbes. (n.d.). Worlds Billionaires List. Retrieved August 5, 2021, from <https://www.forbes.com/billionaires/>

Forster, J. (2018, February 19). How Accurate Should Your Mechanical Watch Actually Be? Hodinkee. Retrieved from <https://www.hodinkee.com/articles/how-accurate-should-your-mechanical-watch-be>

Foulkes, N. (2018, September 20). Why Jean-Claude Biver is so much more than a successful Swiss watch boss. GQ magazine. Retrieved from <https://www.gq-magazine.co.uk/article/why-jean-claude-biver-is-ahead-of-his-time>

G-Shock. (n.d.). Birth Concept G-Shock. Retrieved July 28, 2021, from <https://www.gshock.com/technology/birth-concept>

G-Shock. (n.d.). G-Shock History. Retrieved July 28, 2021, from <https://g-shock.co.uk/history>

Gerald Genta Heritage. (n.d.). His Story. Retrieved July 28, 2021, from <https://www.geraldgenta-heritage.com/gerald-genta>

Gerald Genta Heritage. (n.d.). Iconic Models. Retrieved July 29, 2021, from <https://www.geraldgenta-heritage.com/iconic-models>

Gerald Genta. (n.d.). Homepage. Retrieved July 28, 2021, from <https://www.geraldgenta.com/>

Gold Hub. (n.d.). Homepage. Retrieved July 30, 2021, from <https://www.gold.org/goldhub>

Gurney, J. (2020, November). The rise of the designer. I-M Time Magazine Retrieved from https://ericgiroud.com/images/EG/pdf/I-M_TimeMagazine_Supplement_24112020.pdf

Guttman, M. (2019). Historians on Leadership and Strategy. Retrieved from https://www.researchgate.net/publication/336219316_Industrial_Leadership_and_the_Long-Lasting_Competitiveness_of_the_Swiss_Watch_Industry

Haute Horlogerie Journals. (2015). Directory of market studies for luxury and Fine Watchmaking 2015 [EPub]. Retrieved from https://www.hautehorlogerie.org/fileadmin/user_upload/PDF/Directory_of_market_studies_2015.pdf

Haute Horlogerie. (n.d.). History of watchmaking. Retrieved July 30, 2021, from <https://www.hautehorlogerie.org/en/watches-and-culture/encyclopaedia/history-of-watchmaking/>

In conversation with Japanese watchmaking legend Kikuo Ibe. (2020, March 6). Revolution Watch [YouTube Channel]. Retrieved July 2021, from https://www.youtube.com/watch?v=YaXtLN9NtRg&t=378s&ab_channel=Revolution_Watch

Inflation calculator. (n.d.). Calculator. Retrieved August 10, 2021, from <https://www.inflationtool.com/japanese-yen>

Jean Claude Biver talks Hublot. (2013, October 16). Jason Lim [YouTube Channel]. Retrieved July 25, 2021, from https://www.youtube.com/watch?v=FkaYXYVNb7g&t=980s&ab_channel=JasonLim

Jones, G., Atzberger, A. (2015, September 15). Hans Wilsdorf and Rolex. Harvard Business School. <https://www.hbs.edu/faculty/Pages/item.aspx?num=32369>

Kering. (n.d.). Houses. Retrieved July 28, 2021, from <https://www.kering.com/en/houses/>

King, A.A., Baatartogtokh, B. (2015, September). How Useful Is the Theory of Disruptive Innovation? MIT Sloan Management Review. Retrieved From https://www.researchgate.net/publication/283877064_How_Useful_Is_the_Theory_of_Disruptive_Innovation

Kozák, T. (2019). How disruptive technologies influence the retail business models. International journal of multidisciplinary in business and science. Retrieved from <https://hrcak.srce.hr/228428>

Kuratko, D.F., Goldsby, M.G., Hornsby, J.S. (2018). Corporate Innovation: Disruptive Thinking in Organizations.

Larson, C. (2016, November 15). Disruptive innovation theory: What it is & 4 key concepts. Retrieved from <https://online.hbs.edu/blog/post/4-keys-to-understanding-clayton-christensens-theory-of-disruptive-innovation>

Lim, Y.M. (2015). Lessons learnt from the Marketing Strategy of Swatch Watch in 1980s. Retrieved from <https://core.ac.uk/download/pdf/148781218.pdf>

LVMH. (n.d.). Capital Structure. Retrieved July 28, 2021, from <https://www.lvmh.com/investors/lvmh-share/capital-structure/>

Marche, B., Boly, V., Ortt, J. (2016, June). Observing innovation impacts on supply chain: the case of the Swatch. International Conference on Engineering, Technology & Innovation. Retrieved from <https://hal.archives-ouvertes.fr/hal-01891266/document>

Mercedes Gleitze. (n.d.). Mercedes Gleitze Biography. Retrieved July 30, 2021, from <https://www.mercedesgleitze.uk/>

Minus4Plus6. (n.d.). Rolex Price Evolution. Retrieved July 27, 2021, from <https://www.minus4plus6.com/PriceEvolution.php#>

Mudambi, R. (2005). Branding Time: Swatch and Global Brand Management. Retrieved August 8, 2021, from https://papers.ssrn.com/sol3/papers.cfm?abstract_id=634566

Nardin, L. (2016). The Magic of Watches: A Smart Introduction to Fine Watchmaking
Patrizzini, O. (2019). “Gérald Genta the master”. Mondani Magazine. Retrieved, from <http://www.opatrizzini.com/assets/articolo-su-gerald-genta.pdf>

Raffaelli, R.L. (2013). Identity and Institutional Change in a Mature Field: The Re-emergence of the Swiss Watchmaking Industry, 1970-2008 (Doctoral dissertation). Boston College University, Boston.

Raffaelli, R.L. (2016, March 14). 'Jean-Claude Biver (B): Leading Change at Hublot'. Harvard Business School. Retrieved from <https://hbsp.harvard.edu/product/415032-PDF-ENG>

Richemont. (n.d.). Portfolio. Retrieved July 29, 2021, from <https://www.richemont.com/en/home/about-us/maisons-portfolio-overview/>

Rolex. (2018). History of Rolex [EPub]. Retrieved from https://newsroom-content.rolex.com/-/media/project/rolex/newsroom/rolex/rolex-newsroom-int/about-rolex/history-of-rolex/en_02_rolex_history_english_2018.pdf

Rolex. (n.d.). Rolex Oyster Case. Retrieved July 29, 2021, from <https://www.rolex.com/about-rolex-watches/oyster-case.html>

Seiko Epson. (n.d.). Seiko Quartz Astron 35SQ. Retrieved August 4, 2021, from https://global.epson.com/company/corporate_history/milestone_products/pdf/05_35sq.pdf

Stephens, C., Dennis, M. (2000). Engineering time: Inventing the electronic wristwatch. The British Journal for the History of Science. Retrieved from https://www.jstor.org/stable/4028031?seq=1#metadata_info_tab_contents

Svijet Medija. (n.d.). Casio G-Shock DW-5600 price. Retrieved July 29, 2021 from <https://www.svijet-medija.hr/art/rucni-sat-casio-g-shock-dw-5600e-1ver/72582>

Swatch Group. (n.d.). Brands and Companies. Retrieved July 28, 2021, from <https://www.swatchgroup.com/en/brands-companies>

Switinbank, R. (2016). Jean-Claude Biver: 'The Watch Industry Is Not in Trouble, The World Is.'. Retrieved August 2, 2021, from <https://www.businessoffashion.com/articles/news-analysis/jean-claude-biver-the-watch-industry-is-not-in-trouble-the-world-is>

Taylor, B. (1993, March - April). Message and Muscle: An Interview with Swatch Titan Nicolas Hayek. Harvard Business Review. Retrieved from <https://hbr.org/1993/03/message-and-muscle-an-interview-with-swatch-titan-nicolas-hayek>

Thomond, P., Herzberg, T., & Lettice, F. (2003). Disruptive Innovation: Removing the Innovators' Dilemma. Knowledge into Practice - British Academy of Management Annual Conference. Harrogate, UK.

Thompson, J. (2017 October 10). Four revolutions parts 1 – 4. Hodinkee. Retrieved from <https://www.hodinkee.com/articles/four-revolutions-quartz-revolution>

Thompson, J. (2018 October 25). Personalities Jean-Claude Biver And The Making Of The Modern Watch Industry. Hodinkee. Retrieved from <https://www.hodinkee.com/articles/jean-claude-biver-making-the-modern-watch-industry>

Twinam, T. (2020, July 30). Trade Shocks and Growth: The Impact of the Quartz Crisis in Switzerland. Retrieved from <https://ideas.repec.org/p/osf/socarx/twscm.html>

US Department of Labour. (1959). Occupational Outlook Handbook (1959 Edition). Ohio State University. Retrieved from <https://babel.hathitrust.org/cgi/pt?id=osu.32435051428043&view=1up&seq=7&skin=2021>

US Social Security. (n.d.). National Average Wage Index. Retrieved August 3, 2021, from <https://www.ssa.gov/oact/COLA/AWI.html>

Zefix – Central Business Name Index. (n.d.). Rolex as foundation in legal form. Retrieved July 30, 2021, from <https://www.zefix.admin.ch/en/search/entity/list/firm/300020?name=hans%20wilsdorf&searchType=default>

Figure sources:

Deloitte. (2020). The Deloitte Swiss Watch Industry Study 2020 [EPub]. Retrieved from <https://www2.deloitte.com/content/dam/Deloitte/it/Documents/consumer-business/The%20Deloitte%20Swiss%20Watch%20Industry%20Study%202020.pdf>

Escapenet Patent Search. (n.d.). Rolex Oyster case patent on July 30, 2021 [Data File]. Retrieved from <https://worldwide.espacenet.com/patent/search/family/004400026/publication/CH143449A?q=Ch143449>

Nudds, R., Broer, R.J. (2020, June 21). Sunday Morning Showdown: PP Nautilus Vs. AP Royal Oak. Fratello Watches. Retrieved from <https://www.fratellowatches.com/audemars-piguet-vs-patek-philippe/#gref>

Raffaelli, R.L. (2016, March 14). 'Jean-Claude Biver (B): Leading Change at Hublot'. Harvard Business School. Retrieved from <https://hbsp.harvard.edu/product/415032-PDF-ENG>

Revolution Watch, Povey, R. (2021, February 19). The Rolex No-Date Submariner - Seven Decades of a Classic. Revolution Watch, Retrieved from <https://revolutionwatch.com/rolex-no-date-submariner-seven-decades-classic/>

Thompson, J. (2017 October 10). Four revolutions parts 1 – 4. Hodinkee. Retrieved from <https://www.hodinkee.com/articles/four-revolutions-quartz-revolution>

List of figures

Figure 1 - Audemars Piguet Royal Oak and Patek Philippe Nautilus	16
Figure 2 - Vision of 'fusion' for Hublot.....	18
Figure 3 - Patent for the Rolex Oyster case	22
Figure 4 - Rolex Submariner Models.....	24
Figure 5 - Swatch models from 80's and 90's	29
Figure 6 - Shipments of smartwatches vs Swiss watches (millions of units)	32
Figure 7 - How do swiss executives rate the impact of smartwatches on their sales	35